

PATH TO AVIATION

INTRODUCING AVIATION TO YOUR STUDENTS.

One of the challenges you probably have is putting a fresh face on a subject you may have covered many times. It can be a daunting prospect, but there is one topic that can take you anywhere you want to go: aviation.

Bringing aviation into the classroom is a great way to combine the fun of aviation and learning. It's important to have the right tools available to help you apply the lessons of flight to your required curriculum.

We've put together 11 modules that answer common questions about flying and tie basic aviation to the subjects like math, physics, history, and science. Use these activities independently or in conjunction with a visit from a local pilot.

If you are thinking about a field trip, research a nearby aviation museum on the Internet, and, if you can, enlist any interested pilots to go with your group for additional insight—and crowd control!

And don't forget aviation's ties to space flight. Your school curriculum may already contain a section on space; you can use aviation as a springboard to demonstrate how the human race started its foray into the atmosphere—and beyond!

You can spark the interest of your students by introducing them to aviation—and that's our goal at the Aircraft Owners and Pilots Association. We encourage you to follow up on this interest and help them achieve their goals by using the resources at the back of the handbook. There you'll find a comprehensive list of resources on aviation, as well as ways to encourage them to consider the many career opportunities in aviation.



FOR MORE INFORMATION

Feel free to use the modules as you wish: photocopy them, add to them, and take what you need from them. You'll find complementary student worksheets at www.aopa.org/path.

CORE SUBJECTS: ENGLISH, SPELLING, LANGUAGE

LEARNING THE LANGUAGE OF AVIATION

is the first step in understanding people who fly. All pilots know that clear communication is key to staying safe in the air. Pilots need to talk to other pilots and air traffic controllers in a concise way that everyone can understand. Miscommunication can cause problems when they are 10,000 feet in the air, taxiing across a runway, and everywhere in between.

While the language of aviation worldwide is English, pilots have developed a sort of universal code to help keep their communications as clear as possible to anyone listening. Pilots use a phonetic alphabet when saying anything they need to spell out, substituting a particular word that begins with the letter they need. Civilian and military pilots around the world—from Albany to Zurich—use the same words for each letter, such as “alpha” for “A” and “zulu” for “Z.”

Add a twist to your next English or spelling lesson. Teach students the phonetic language used by pilots. Explain the need for clear communications regardless of native language or regional accent.

Here is the phonetic aviation alphabet:

A Alpha	R Romeo
B Bravo	S Sierra
C Charlie	T Tango
D Delta	U Uniform
E Echo	V Victor
F Foxtrot	W Whiskey
G Golf	X X-ray
H Hotel	Y Yankee
I India	Z Zulu
J Juliet	
K Kilo	3 Tree
L Lima (LEE-muh)	9 Niner
M Mike	0 Zero
N November	All other numbers
O Oscar	use standard
P Papa	pronunciation
Q Quebec (kuh-BEK)	

PRACTICAL USES

Pilots most frequently use the phonetic alphabet to identify specific airplanes. In the U.S. most aircraft are registered with the Federal Aviation Administration. They provide what is often referred to as the “N” number, since all U.S. airplane registrations start with that letter. An aircraft’s N-number is made up of some combination of letters and numbers painted or affixed to the airplane, similar to a car’s license plate, but large enough to be visible when the airplane is in flight.

ACTIVITY: Radiospeak

Photocopy this activity for classroom use.
Go to www.aopa.org/path for student worksheets.

TEACHERS:

From this activity, students will learn how to use the phonetic alphabet .

SPELL OUT THE FOLLOWING WORDS USING THE PHONETIC ALPHABET:

1. PILOT
2. AIRPLANE
3. SCHOOL
4. Name of your school mascot
5. Your city or town
6. Your first name

HOW WOULD YOU IDENTIFY THE FOLLOWING AIRCRAFT WHEN TALKING TO AN AIR TRAFFIC CONTROLLER ON THE RADIO?



Close-up photo of a Mooney aircraft with the engine cowl removed.

CORE SUBJECTS: MECHANICS, SCIENCE, AERODYNAMICS

THE AIRPLANE IS ESSENTIAL to human flight. It is a heavier-than-air vehicle, powered by an engine that travels through the air via the forces of lift and thrust. Its pieces provide clues to what makes an aircraft move up and down, left and right and side-to-side. Your students may be surprised to learn that small, single-engine airplanes and large jetliners have essentially the same basic parts. They just get bigger as the size of the airplane increases.

Use this as a reference for other activities in this handbook.

THE MAIN PARTS OF AN AIRPLANE

- | | |
|--------------------------|-----------------------|
| 1. Propeller | 10. Rudder |
| 2. Landing Gear | 11. Elevator |
| 3. Right Wing Strut* | 12. Left Wing Flap |
| 4. Wing | 13. Left Wing Aileron |
| 5. Right Wing Aileron | 14. Door |
| 6. Right Wing Flap | 15. Fuel Tanks |
| 7. Fuselage | 16. Windshield |
| 8. Horizontal Stabilizer | 17. Engine Cowl |
| 9. Vertical Stabilizer | |

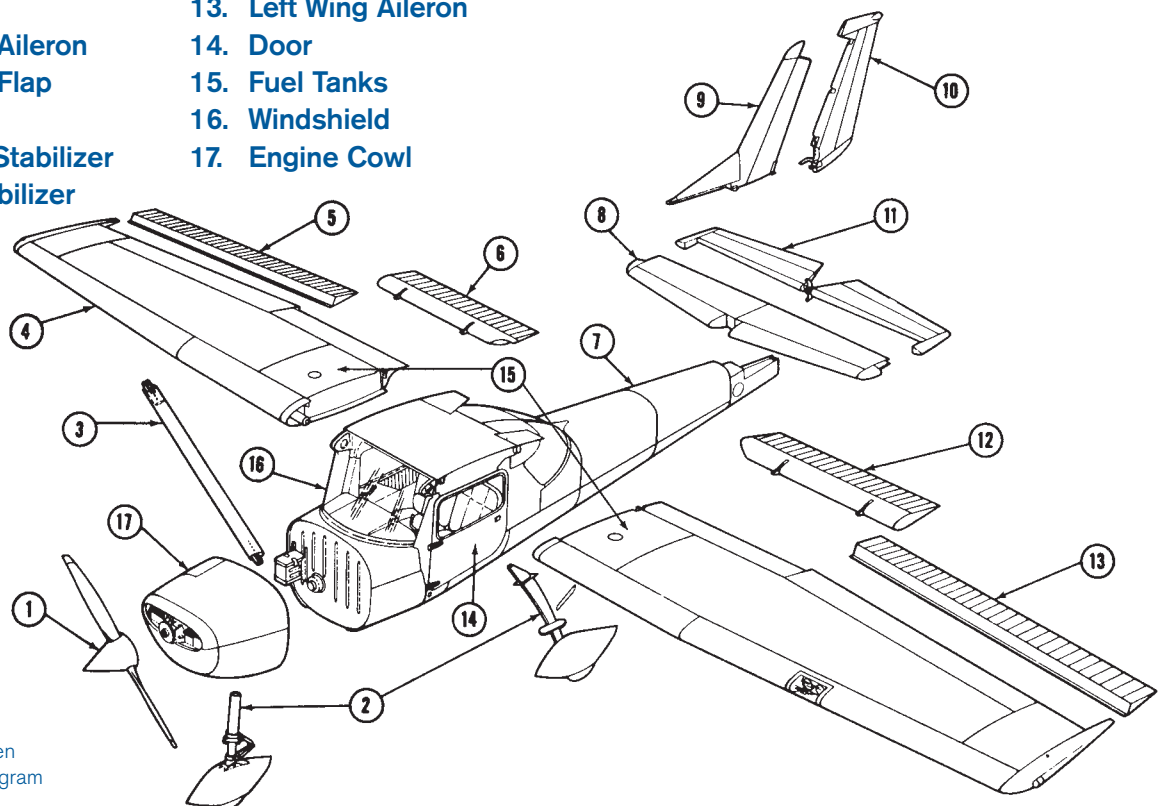

* Left wing strut hidden under wing in this diagram



Photocopy this activity for classroom use.
Go to www.aopa.org/path for student worksheets.

PARTS OF AN AIRPLANE THAT MAKE IT FLY.

Propeller – A propeller is a rotating blade on the front of the airplane. The engine turns the propeller, which pulls the airplane through the air.

Wings – Wings are the parts of airplanes that provide lift. They also support the entire weight of the aircraft and its contents while in flight.

Flaps – Flaps are the movable sections of an airplane’s wings that are closest to the fuselage. They move in the same direction on both wings at the same time, and, by creating drag and lift, enable the airplane to fly more slowly.

PARTS OF AN AIRPLANE THAT HELP CONTROL DIRECTION OF FLIGHT.

Ailerons – Ailerons are the movable sections on an outer edge of an airplane’s wings. They move in opposite directions (when one goes up, the other goes down). They are used in making turns by controlling movement along the **longitudinal axis** (an invisible line through the airplane from the nose to the tail).

Rudder – The rudder is the movable, vertical section of the tail that controls lateral (side-to-side) movement along the **vertical axis** (an invisible line through the airplane perpendicular to the longitudinal axis). When the rudder moves in one direction, the aircraft nose moves the same direction.

Elevator – The elevator is the movable, horizontal section of the tail that causes the airplane to climb and descend. When the elevator moves one direction, the nose moves in the same direction (up or down). This movement is along the **lateral axis** (an invisible line that runs from wing tip to wing tip).

OTHER PARTS OF AN AIRPLANE

Fuselage – The fuselage is the central body of an airplane, designed to accommodate the pilot/crew and the passengers and/or cargo.

Cockpit – In general aviation airplanes the cockpit is the space within the fuselage where the pilot sits and controls the airplane.

Landing Gear – The landing gear is underneath the airplane and supports it while on the ground. The landing gear usually includes two main wheels and a nose- or tailwheel.



Longitudinal axis

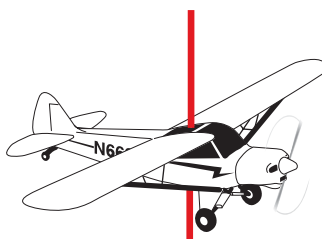

Vertical axis

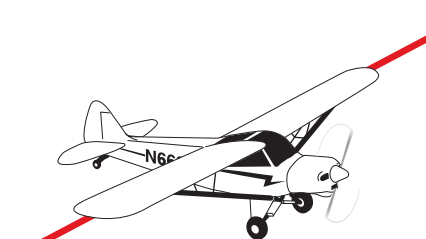

Lateral axis

CORE SUBJECTS: AERODYNAMICS, MECHANICS, ENGINEERING

FLIGHT CONTROLS OF AN AIRPLANE

are surprisingly simple and, although the systems may get more complex on larger airplanes, the basic principles are the same for anything from a trainer aircraft to the largest of airliners.

You may have wondered why airplanes bank (lean to one side) as they turn. The reason is that airplanes turn by directing the lift of their wings more to one side or the other. This is done by moving control surfaces on the wings known as ailerons. When you turn the control wheel (also known as the yoke), the aileron on one wing deflects upward, while the aileron on the other wing goes down. This increases and decreases lift on the wings.

Climbing and descending is directed through use of movable control surfaces on the horizontal portion of the tail. Appropriately enough, they are called eleva-

tors and are activated by pushing the control wheel forward or pulling it back.

The third basic control for flying an airplane is the rudder. Contrary to what you might expect, the rudder alone does not steer the airplane but rather serves the purpose of properly aligning the airplane in flight. The pilot controls the rudder's movement with rudder pedals on the floor of the airplane and also uses them to steer the airplane's nosewheel or tailwheel when on the ground.

Note: adapted from "You Can Fly!" by Gregory N. Brown and Laurel Lippert



A typical cockpit in a single-engine aircraft.

FLIGHT CONTROLS OF AN AIRPLANE

YOKE CONTROLS

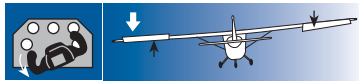

When you turn the yoke left, the left aileron goes up, the right aileron goes down (black arrows), the left wing goes down (white arrow), and the airplane banks left.



When you turn the yoke right, the right aileron goes up, the left aileron goes down (black arrows), the right wing goes down (white arrow), and the airplane banks right.



When you push the yoke forward, the elevator goes down (black arrow), forcing the tail up, and the nose goes down (white arrow).



When you pull the yoke back, the elevator goes up (black arrow), forcing the tail down, and the nose goes up (white arrow).

RUDDER PEDAL CONTROLS

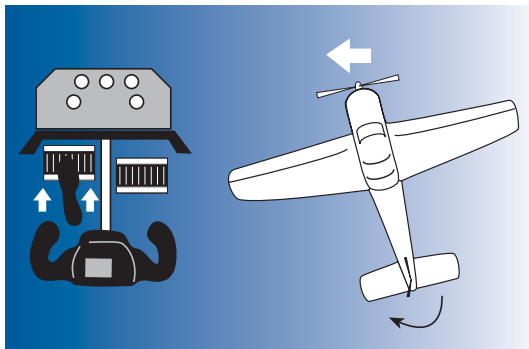

Push the left rudder pedal and the rudder on the tail moves left (black arrow), forcing the tail to the right and the nose moves left (white arrow).

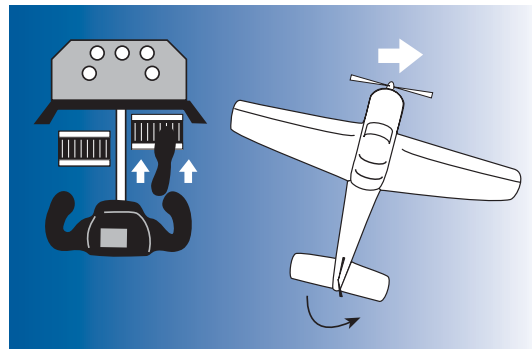

Push the right rudder pedal and the rudder on the tail moves right (black arrow), forcing the tail to the left and the nose moves right (white arrow).

ACTIVITY: Building a glider

Photocopy this activity for classroom use.
Go to www.aopa.org/path for student worksheets.

TEACHERS:

From this activity, students will learn how control surfaces—the moving parts on the wing and tail—control which way an airplane turns and moves through the air.

MATERIALS:

Sheet of paper
Paper clips
Room to throw

TO DO IT:**Folded Paper Glider**

1. Fold paper in half lengthwise and crease.
2. Fold down the corner of one side so the edge is even with the folded side of your original crease. Flip paper over and repeat to form a point.
3. Fold down the angled edge on one side so it is even with your original fold. Flip and repeat. You should now have a more narrow point.
4. Make a third fold that brings your new top edge even with the bottom of your original fold.
5. Push up the wings so they are perpendicular to the body of your airplane. Try launching your airplane

(Tip: If it seems "nose heavy" use paperclips near the rear of the airplane to add weight and help keep the nose up. You may need 2-3 paperclips)

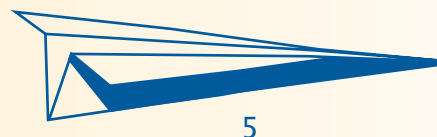
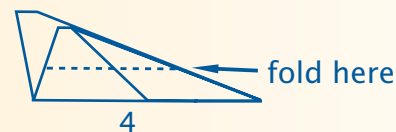
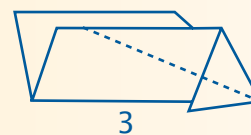
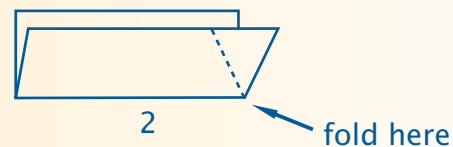
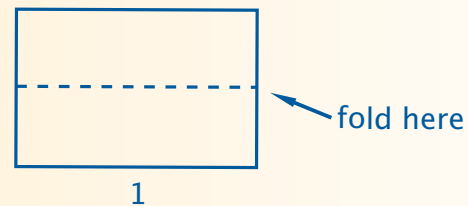

ACTIVITY: Building a glider

Control Surfaces – Up and Down

Once you have gotten your airplane to fly relatively straight, gently tear the back edge of each wing to create elevators. One-half to three-quarters of an inch should be enough.

Bend your elevators up slightly and see what impact it has on the flight path. Bend them down and try again.

(Tip: Down position should cause the nose to go down faster. Up should help your airplane ascend or stay aloft longer.)

Look for modest changes in float direction. The average paper airplane only stays aloft for a few seconds.

When the pilot wants the airplane to climb, he moves the airplane controls so that the elevators tilt up in the same way that you folded back the edges of your glider. The air hitting the elevators pushes the tail of the airplane down, tilting the nose upward, so the airplane can climb.

Control Surfaces – Right and left

Now try the rudder or vertical fin. Tearing your elevators should have left you with a 1/2 - 3/4 inch portion of your airplane's body that can be folded left or right. Try folding it slightly left or right and test the impact on your airplane's flight path. Left or right folds should send your airplane left or right, respectively.

UP AND DOWN

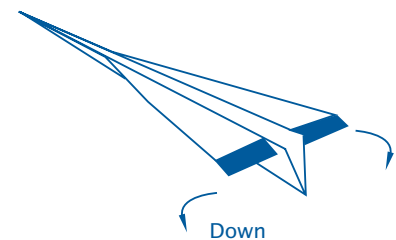
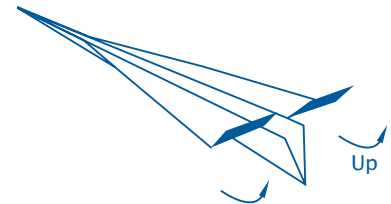

RIGHT AND LEFT

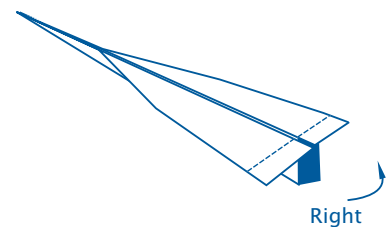

CORE SUBJECTS: PHYSICS, AERODYNAMICS

WHEN AN AIRPLANE PASSES OVERHEAD

its flight looks effortless. You probably wonder how gravity allows something that large to stay aloft. An airplane is a machine that balances the forces of gravity with lift to make it fly.

Gravity acts on the airplane in flight just as it does on people and objects on the ground. **Lift** overcomes gravity and allows the airplane to fly. Lift is created when the forward motion of the airplane causes air to flow over those wings (also called an airfoil).

Several principles combine to explain how lift is created. These include Newton's laws of motion and Bernoulli's principle on the motion of fluids.

You may be familiar with Newton's third law of motion that states "for every action there is an equal and opposite reaction."

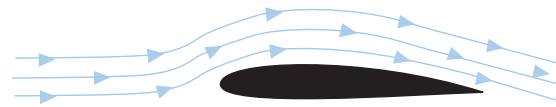

Newton's third law of motion applied to an airfoil

Well, that's one law that the wings obey as they move through the air. As the air flows over a wing's upper surface, it bends downward. The "opposite reaction" is a push upwards, which is part of lift.

Also, air flowing over the longer distance of the curved upper wing surface, must travel faster than the air flowing the shorter distance under the flatter bottom surface of the wing.



A Cirrus SR20 flies over a dense forest. Trees can block wind on the ground and force it to change direction. (see module 7)

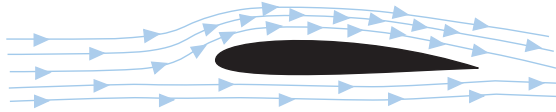

According to Bernoulli, air must move faster to cover more distance in the same time as air moving the shorter distance below the wing.

According to Bernoulli's principle, the difference in the speed of the air, which behaves like a fluid, produces lower pressure above the wing than below it. This pressure difference produces lift as well.

Most small airplanes have engines and propellers mounted in the front. The power pro-

duced by the engine is translated into **thrust** by the propeller, which pulls the airplane through the air. You feel a similar kind of thrust when a driver pushes the accelerator pedal in a car.

Thrust also works to counter the effects of **drag**, which is created by resistance against all of the surfaces of the airplane that impact the wind (and the development of lift). If you've ever been on a roller coaster and waved your arms as you sped along the track, or held your arm out an open car window, you have felt the drag created by air resistance.



ACTIVITY: Airfoil design



Photocopy this activity for classroom use.
Go to www.aopa.org/path for student worksheets.

TEACHERS:

From this activity, students will learn how the shape of an airfoil influences how well that airfoil develops lift.

MATERIALS:

Paper
Tape
Plastic straw (cut in thirds)
String
Scissors
Single-hole punch
Electric box fan

TO DO IT:

- ▶ Bend the paper in half without creasing the fold.
- ▶ Punch a hole in the paper through both sides of the paper. Where you place the hole will determine the shape of your airfoil, or wing.
- ▶ Slide the straw through the holes and secure the straw to the paper with tape.
- ▶ Look at the wing from the side. Can you guess how well it will create lift, based on what you have just learned about Newton's and Bernoulli's theories?
- ▶ Insert the string through the straw so that the airfoil can slide up and down on the string freely. Hold both ends of the string so that your airfoil does not fall off.
- ▶ Set up the fan so that you can hang the airfoil in the air stream. With the fan off, position the airfoil and hold it so that it is perpendicular to the airflow, just as an airplane might fly its wing through the air.
- ▶ Holding both ends of the string, turn the fan on low, and watch the airfoil to see if it rises on the string—a sign that lift is being produced.
- ▶ Try different speeds on the fan, and various airfoils created by other students. Compare how well they work with the shape of each airfoil.

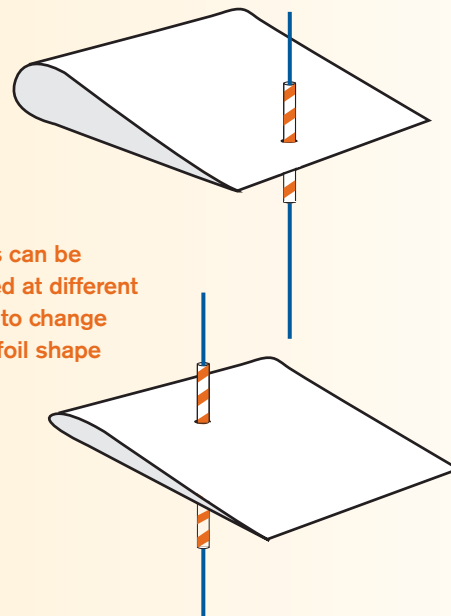

Straws can be inserted at different points to change the airfoil shape



A Piper 6X lifts off the ground to start its flight.

CORE SUBJECTS: PHYSICS, MATHEMATICS

IF YOU'VE EVER STRUGGLED TO WALK UP

stairs with a heavy suitcase or grocery bags, or get up from your chair after a full holiday meal, you've experienced a key concept about flying: It takes more energy to move a larger mass than it does a smaller one. Similarly, it takes more energy to make a large, heavy airplane fly versus a small, light one. A Boeing 747 has the thrust to move way more mass than its little Cessna or Piper brethren. But, if you overload any airplane, you can roll down the length of the runway and never leave the ground—the airplane just can't generate enough lift to overcome the heavy weight.

Aircraft engineers set design limits on airplanes before they leave the factory, and these specifications tell the pilot how much weight the aircraft can handle—whether that weight is represented by people, bags, or fuel. Pilots carefully calculate the weight that they put on the airplane before they take off. Because if they don't, the results can be grim.

Not only does the total weight have to be less than certain absolute limits, it can't be put in the wrong place either. Ever try to jam a heavy load into the trunk of a car, only to watch the rear end sink to the axle? That's no good for the car, to be sure, but a similarly out-of-kilter condition bodes even worse for an airplane.

An airplane balances on two points as it flies through the air, its *center of gravity (CG)* and its *center of pressure* or *center of lift*. The center of pressure is determined by where the total lift created by the wings is concentrated, an average of all the lift vectors emanating from the wing's upper surface. Likewise, the CG is the fulcrum point of balance for all the weight on board the airplane, and the airplane itself (including the wings, the engine, and the fuel).

The center of pressure and the CG work in conjunction to determine the airplane's longitudinal or *pitch stability*. An airplane is typically designed so that its center of pressure is located aft of the CG. This creates a situation in which, if the airplane's nose is

abruptly pitched downward, the aerodynamic forces on the airplane will cause it to pitch back up, returning it to level flight.

The CG of the empty airplane is usually located somewhere along the airplane's fuselage near the intersection of the cabin and wings; in most cases this empty CG is close to an optimum CG for the airplane. The farther a weight is placed from the CG, the more it can move the CG away from the optimal position. This is why the fuel tanks are often located near the empty CG of the airplane, so they can be filled without adversely affecting the CG. Consequently, as the airplane uses up the fuel, the change in weight doesn't affect the airplane adversely in flight.

Airplanes have a CG range in which normal operations are possible. If you put a heavy weight near the tail of the airplane, and thus take the airplane out of its operational CG range, the airplane may be too nose-high and therefore difficult or impossible to control. On the other hand, if you move weight too far forward, and ahead of the operational CG range, you may make the airplane so nose heavy that you cannot pull back on the controls hard enough to lift off the runway on takeoff.

Either way, too much weight or too much weight in the wrong place can be hazardous to flying an airplane.



The weight of the pilot and any passengers affect the aerodynamics and handling of an airplane.

ACTIVITY: Weight and gravity

Photocopy this activity for classroom use.
Go to www.aopa.org/path for student worksheets.

TEACHERS:

From this activity, students will learn how to determine the Center of Gravity of an object. They'll also learn how the Center of Gravity can shift when weight is placed in different locations on the same object.

MATERIALS:

Yardstick or ruler

Two rolls of masking tape

Stickers to label different points on the yardstick (tape will work too)

TO DO IT:

If an object weighs anything, it has a Center of Gravity or CG. As a reminder, this is the fulcrum point at which all the weight in an object balances. It is harder to find the CG on an irregular-shaped object like an airplane, but pilots must be aware of where the CG is during flight and exactly how changes in where weight is placed can affect the CG.

Engineers provide an optimal CG that provides the best overall performance of the airplane. While the placement of fuel is held constant by the location of the fuel tanks, engineers also provide pilots with the best options for placing weight, such as passengers and cargo, so that the CG does not move too far from its optimal position. See for yourself the effect of weight movement on the CG.

- ▶ Balance the yardstick on your finger until it hangs evenly. Mark this point on the yardstick with masking tape and label it CG1.
- ▶ Tear off a long enough piece of masking tape from one roll to affix the other roll of tape to the yardstick. Pick any point.
- ▶ Try and balance the yardstick on your finger at CG1. What happens? Now find the new CG for the yardstick. Mark it CG2.
- ▶ Take the same roll of tape and move it somewhere else along the yardstick away from CG1. Find the CG and mark it CG3. The yardstick with one roll of tape attached weighs exactly the same. Is the CG in the same place now that the weight has shifted? If it has moved, how far has it moved, relative to how far the weight moved?
- ▶ Have students take other common objects around the classroom and balance them to determine the CG.

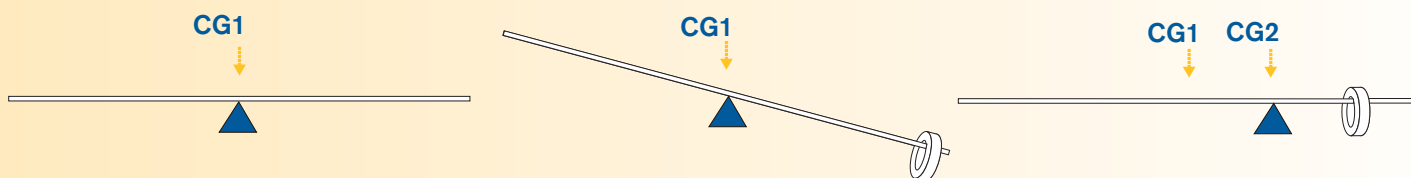

ACTIVITY: Center of gravity

Can you guess where the Center of Gravity is on these airplanes?



CORE SUBJECTS: EARTH SCIENCE, ATMOSPHERIC SCIENCE

ALTITUDE, ATTITUDE, AND SPEED

are just a few of the things pilots monitor during every flight. Pilots initially learn to control the airplane by looking out the window and using the horizon as reference. Most airplanes, however, have an array of gauges and indicators, known as flight instruments, in a panel similar to the dashboard of a car. The panel of flight instruments provides the pilot with critical information about his or her airplane while flying. You can use the basic gauges of an aircraft to introduce your students to the concepts of airspeed, altitude, attitude or position, as well as how to use a compass.

SIX INSTRUMENTS COMMON TO MOST GENERAL AVIATION AIRCRAFT:

AIRSPPEED INDICATOR



A gauge that displays the airplane's speed through the air, based on the difference between ambient air pressure

and ram air pressure. Typically shows airspeed in knots (nautical miles per hour) or in miles per hour.

ATTITUDE INDICATOR OR ARTIFICIAL HORIZON



An indicator that shows whether the airplane is pitched up or down, or banked (tilted) left or right. Here the orange bars indicate

wing position relative to the ground as shown by the white line.

ALTIMETER



3 A highly sensitive barometer that shows an airplane's altitude above sea level by measuring ambient pressure. The large numbers mark hundreds (long hand) or thousands (short hand) of feet.

TURN COORDINATOR



4 A gyro-based instrument that shows the tilt of the wings. The position of the ball indicates if the airplane is in a coordinated turn. A turn is "coordinated" if the rate of turn is appropriate for the amount of bank angle.

HEADING INDICATOR OR DIRECTIONAL GYRO



5 An indicator that displays aircraft heading, based on the 360-degree compass rose. The pilot sets the heading indicator based on the aircraft's magnetic compass prior to taking off, and checks it against the compass in flight to ensure it stays accurate.

VERTICAL SPEED INDICATOR



6 An instrument sensitive to changes in ambient air pressure. It takes the rate of change and displays it as rate of climb or descent. Reads in hundreds of feet per minute.

DEFINITIONS

Ambient air pressure: The pressure of the air that is around you and the aircraft. Air pressure decreases as altitude increases, so the changes in ambient air pressure affect the aircraft's altimeter.

Ram air pressure: The pressure of air as it is forced into a forward facing inlet. In general aviation, when the airplane moves forward, air is forced into an instrument called a pitot tube that is

affixed to the wing. This ram pressure is compared against the undisturbed air in a static port to determine the airspeed of the aircraft.

ACTIVITY: Panel decoder



Photocopy this activity for classroom use.
Go to www.aopa.org/path for student worksheets.

TEACHERS:

From this activity, students will learn how to read the instruments and establish relationships between the indications on the instruments and the airplane's flight path.

TAKE A LOOK AT THE FOLLOWING PANEL AND SEE IF YOU CAN FIGURE OUT WHAT THE INSTRUMENTS ARE TELLING YOU.



Numbers in photo refer to instrument descriptions in the opening pages of this module

QUESTIONS:

1. What is the airplane's indicated airspeed?
2. At what altitude is the airplane?
3. Is the airplane in a turn? What two instruments can you look at in order to know?
4. Is the airplane climbing or descending? What instrument(s) are you looking at in order to make this conclusion?
5. What direction is the airplane headed at this moment?
6. Based on your answer to Question #3, is the airplane's heading changing or staying the same?
7. If power has remained constant, based on your answer to Question #4, do you think the airspeed is increasing, decreasing, or remaining constant?
8. How long will it take the airplane to descend 1,000 feet?



This is an example of the advanced flight control systems now available in many small airplanes. Compare the information on these displays to the instrument gauges on pages 33-35.

CORE SUBJECTS: EARTH SCIENCE, ATMOSPHERIC SCIENCE

FROM THE MOMENT YOU JUMP into a pool or lake or the ocean you have entered the water; whatever qualities the water possesses affect you directly. If the water is cold, you shiver. If the waves are high, you ride their crests and troughs. The current, if any, pulls you as you swim.

When pilots launch their airplanes into the sky, they too become inextricably connected to the “ocean” of air around them. So pilots must study the ways weather distributes the cold and heat, forms the wind, and creates the precipitation we experience on the ground as rain, snow, and sleet.

Students have been affected by changes in weather patterns since they were little and their parents either lathered them with extra sunscreen on a sunny day or bundled them up with an extra sweater during a snowstorm. Teaching weather, its causes and effects, does not have to be a theoretical lesson of one invisible air mass hitting another invisible air mass. Place an airplane in the middle of your lesson and let students determine what impact the weather systems would have on the path of that airplane. Would they want to fly today—or tomorrow—through the path of an oncoming thunderstorm? Or would a small airplane get bounced around too much in wind gusts and heavy rain?

What is weather? The sun heats the earth unevenly, creating *air masses* (or regions of air) of varying density, and causing air to circulate over the globe. This heating, along with other factors, also develops areas of

relatively high and low pressure. Air tends to flow from areas of high pressure to areas of low pressure, which we experience as wind.

DEFINITION

Frictional Force: The surface of the Earth exerts a frictional drag on the air blowing just above it. How much friction changes with differences in terrain and whether or not the wind blowing has to slow down or change direction to move up, down and around any trees, mountains, etc.

High or low pressure is typically depicted on weather maps as H’s and L’s. Generally, good weather is associated with highs, while poor weather is often found in the lows. If you watch the weather forecasts on television or download weather maps from the Internet you can compare where the H’s and L’s are positioned to where the rain or snow is falling—and often make a connection.

Wind causes air masses to move, and they encounter other air masses that have different characteristics. The boundary between

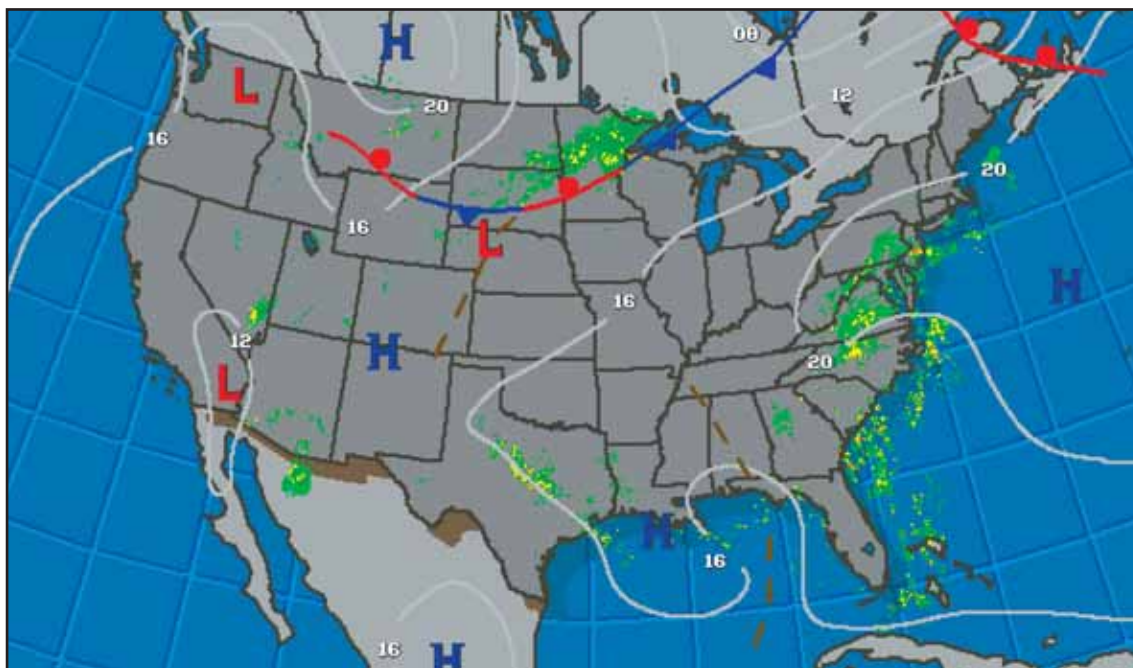

two air masses is called a *front*. Weather along fronts may be hazardous to pilots because of the clouds, precipitation, and turbulent air (*turbulence*) that it can produce. A *cold front* is where a cold air mass displaces warmer air. A *warm front* is where warm air displaces colder air. *Stationary fronts* have no movement.

DEFINITION

Windshear: A quick change in the speed and/or direction of wind.

Temperature, wind, and ambient air pressure change as a front passes by.

Pilots watch the areas of high and low pressure and the movement of fronts to determine what the weather will be like for an upcoming flight. In particular, they look at the clouds, precipitation, wind, and convective activity associated with the weather patterns to make the decision to fly or not.

You know convective activity if you've ever witnessed a thunderstorm. Heating of the earth's surface also causes clouds to build if enough moisture is present in the air. When conditions are ripe, clouds tower into *thunderstorms*, sending heavy rain, hail, strong gusty winds, and sometimes tornadoes, into the area covered by the storm. Thunderstorms are dangerous for airplanes because they combine a number of hazards into one area.

Precipitation, in the form of rain, snow or sleet, can determine whether or not a pilot is able to proceed. Heavy rain can reduce visibility. Snow can block engine air intakes, affecting the engine performance. water droplets adhere to the airplane in the form of ice, changing both the weight and the shape of the wings and other components, decreasing the airplane's ability to produce lift. Wind affects the airplane's speed over the ground, and also may create turbulence or wind shear. Turbulence caused by gusty winds can range from uncomfortable bumps to severe jolts that render the airplane uncontrollable.

ACTIVITY: Reading weather maps



Photocopy this activity for classroom use.
Go to www.aopa.org/path for student worksheets.

TEACHERS:

From this activity, students will learn how to glean the basics from weather forecasts and try to predict how the weather will change in the near future.

MATERIALS:

Weather charts for a five-day period.

Current surface analysis charts and forecasts can be found at <http://adds.aviationweather.gov/progs> or go to www.intellicast.com and click on “Current Surface Analysis” for current conditions or click on the “US Weather” tab and “Surface Analysis” for more options.

Other free sites include the National Weather Service at www.nws.noaa.gov or the Weather Channel at www.weather.com

TO DO IT:

Meteorologists use complex models involving physics and mathematics to predict the weather. But they also consult weather maps that are available to you to make a rough estimate of what the future weather holds. They often look at surface analysis charts, which show the conditions at a given time. By looking at several days’ worth of maps, you can look at how the weather has moved from one place to another, how it appears to build or dissipate, and how that weather may have affected pilots flying in that region. You also can take a guess at what the weather will bring to you in the next few days.

- ▶ Print out the surface analysis charts (or current conditions maps) for five days in a row from the web sites listed above.
- ▶ On the first chart, identify the areas of high and low pressure, and the fronts depicted on

the chart. Cold fronts are in blue, and marked with triangles; warm fronts are in red, and marked with half circles.

- ▶ Where are the areas of precipitation associated with each front? Each low?
- ▶ Now do the same for the next four days’ worth of charts. How are the fronts moving? What happens to the highs and lows as they move?
- ▶ Wind tends to parallel a frontal boundary ahead of the front, and pushes from behind a front once the front passes. Can you mark on the chart the direction you think the wind is blowing in each case? Is the wind too strong for a small airplane to fly?
- ▶ Spot your city or town on the chart. What has the weather been like in your area during the days for which you have charts? How does that weather correlate with the highs and lows and fronts you see on the chart?
- ▶ Based on the charts, what would you expect the weather to be like tomorrow? Test your forecast by writing it down and comparing it to tomorrow’s actual weather.

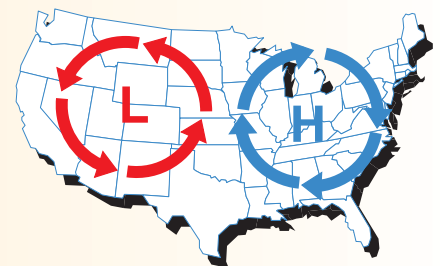

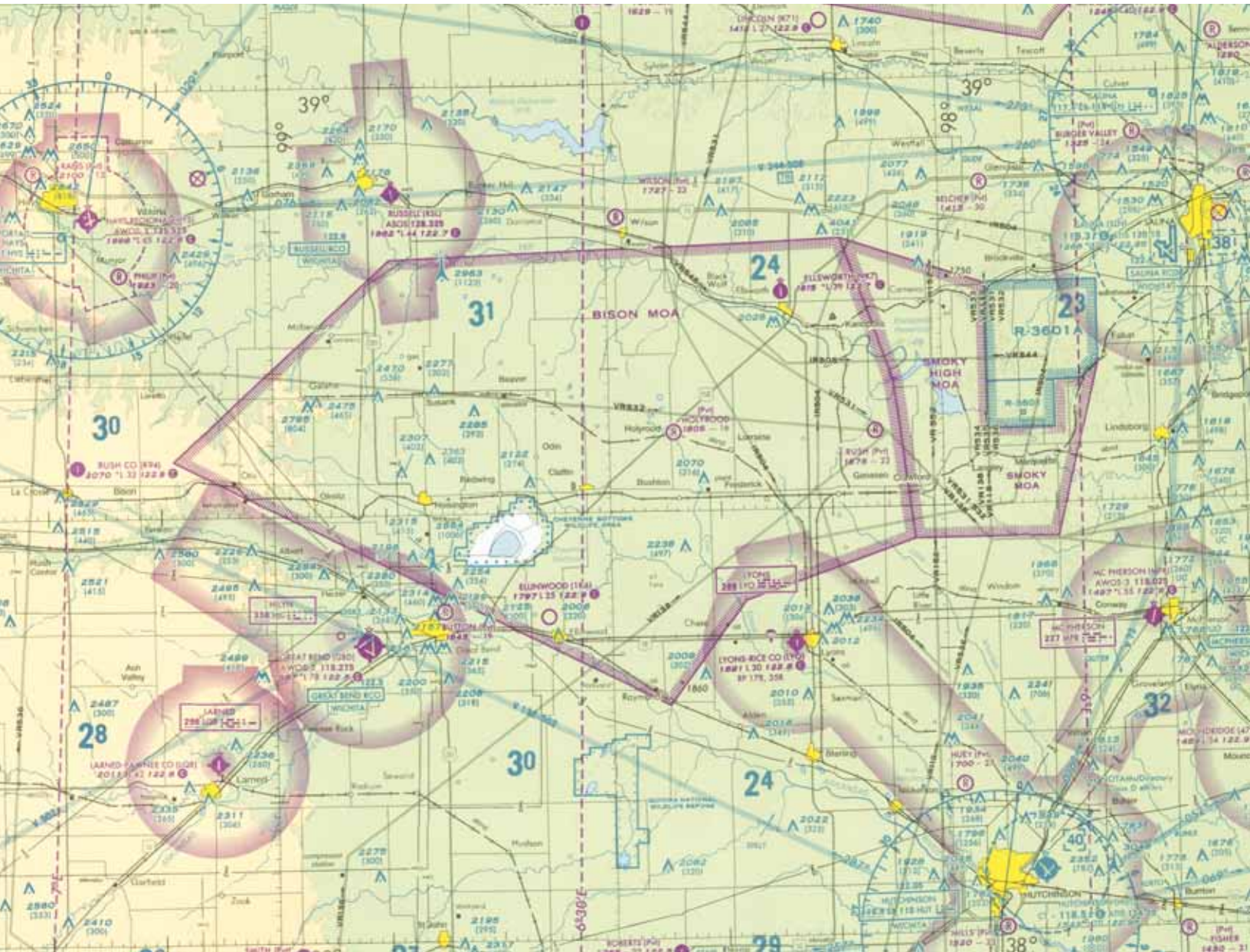

CORE SUBJECTS: MATHEMATICS, GEOGRAPHY

PROPER PLANNING PREVENTS POOR PERFORMANCE

—and that’s especially true when it comes to planning a flight! Pilots spend quality time before every flight researching the information they need to make that flight safe—and more fun. They answer questions such as: At what airport should I land? How long are the runways? Can I get fuel? And, most important: Is there a good restaurant at the airport?

To explore the nuances of flight planning, we’ll look at two comparative flights from the Wright Brothers home of Dayton, Ohio, to the area of the first powered flight, near First Flight Airport, North Carolina.

We’ll plan one flight using approximate data for the *Wright Flyer*, the very first powered airplane to make a controlled flight. We’ll take some liberties here; for instance we will assume that the aircraft could structurally make the trip, that it had enough fuel on board for the trip, and that it could

reach an altitude sufficient for all terrain clearance. An identical flight will be planned using approximate data for a Piper Archer, a popular four-seat, single-engine airplane.

From these two flight-planning examples, we introduce the students to the concepts of temperature conversion, working with aircraft ground speed, wind direction and speed, distance to travel, weather, fuel usage, and other aviation issues relating to math and science.



A manual flight computer called E6-B is used to plot flight paths. Every student pilot learns to use an E6-B.



A student pilot uses an aeronautical ruler to mark a flight path.

ACTIVITY: From Dayton to First Flight



Photocopy this activity for classroom use.
Go to www.aopa.org/path for student worksheets.

TEACHERS:

From this activity, students will apply the basics of flight planning like a general aviation pilot.

MATERIALS:

Calculator

TO DO IT:

1. Pilots measure temperature in degrees Celsius rather than Fahrenheit. The following formula is used to convert from one to the other.

$$^{\circ}\text{C} = 5/9 \times (^{\circ}\text{F} - 32)$$

Calculate the following temperature in degrees Celsius:

- (a) 32°F (b) 100°F (c) 54 °F (d) 88°F

2. Pilots often need to squeeze a great deal of information into a small space. Here is an example of a weather report for pilots.

METAR KMGY 052020Z AUTO 03016G23KT 3SM BKN004 OVC014 30/22 A2990

What does it all mean? Let's break it down for you.

METAR KMGY 052020Z AUTO 03016G23KT 3SM BKN004 OVC014 30/22 A2990

meteorological report	airport Identifier (Dayton-Wright Brothers, OH)	5th day of the month, 8:20pm Greenwich Mean Time (Zulu Time)*	automated report	wind from 30 degrees at 16 knots, gusting to 23 knots	visibility is 3 statute (standard) miles	cloud cover is broken at 400 feet above the airport and overcast at 1400 feet above the airport	temperature is 30 degrees Celsius, dew point is 22 degrees Celsius	barometric pressure is 29.90 inches of mercury
-----------------------	---	---	------------------	---	--	---	--	--

Can your students translate the following weather report? When you have a pilot visit your classroom, ask her to bring a weather report for the day for the students to practice.

METAR KFFA 102107Z 01005KT 10SM 26/16 A3012

* Greenwich Mean Time (GMT) is international time, the basis of the world time clock. It helps eliminate confusion across multiple time zones. It is called Zulu Time in aviation and other applications. Greenwich, England, was chosen as "zero hour" because it is latitude 0 degrees 0 minutes 0 seconds. If you live in the east, your Zulu Time is GMT minus four hours (five hours for daylight savings time); if you live in the west your Zulu Time is GMT minus 7 hours (or 8 for DST). So if you're in New York City at it's noon, your Zulu Time is 0800Z (or 0700Z for DST). Because Zulu Time is based on a 24-hour clock, if it's 5:00 PM (DST) in New York City, that would be 1200Z (5 PM is 1700 hours so it's 17 minus 5). GMT is also known as UTC (coordinated universal time). For more information see <http://www.greenwichmeantime.com>

ACTIVITY: From Dayton to First Flight

Answer Key:
1. (a) 0° Celsius (b) 37.7° C (c) 12° C (d) 31° C 2. Aviation routine weather report for First Flight Airport, 10th day of the month, 9:07 Zulu; wind 10 degrees at 5 knots; visibility 10 statute miles; sky clear below 12,000 feet; temperature 26 degrees Celsius; dew point 16 degrees Celsius; barometer 30.12 inches of mercury 3. (a) 174 kts (b) 87 kts (c) 87 mph (d) 115 mph (e) 58 miles (f) 115 miles (g) 235 nm (h) 22 nm 4. Dr. Speedy will arrive in 2 and a half hours; Mr. Tooslo will arrive in 6 hours and 4 minutes. 5. Runway 2 6. Same course (the wind is directly behind us), 140 kts 7. Piper Archer: 48 gallons, 9 gallons per hour; it will make it. Wright Flyer: 1 gallon per hour; it must refuel at least every hour. 8. To the left or east. 9. Runway 22

3. Pilots measure flight distance in nautical miles as well as statute miles that we use on the ground level. One nautical mile (nm) equals 1.15 statute miles; so one nautical mile per hour (knots) equals 1.15 statute miles per hour (mph). Translate the following distances:

To knots:

- (a) 200 mph
- (b) 100 mph

To mph:

- (c) 76 knots
- (d) 100 knots

To statute miles:

- (e) 50 nm
- (f) 100 nm

To nautical miles:

- (g) 270 miles
- (h) 25 miles

4. Dr. Ivan M. Speedy just bought a Piper Archer that can fly at 120 knots. W. A. Tooslo has a vintage *Wright Flyer* that flies at 32 mph. They are both planning to leave at the same time and fly to the airport in Dayton, Ohio. If Dr. Speedy lives 300 nautical miles away, and Mr. Tooslo lives 170 nautical miles away, who will arrive first?
5. Before departing Dayton, we need to decide what runway we are going to use. Runways are numbered according to magnetic degrees with one zero removed (see module 9 for a full explanation). If Dayton has runways 2 and 20, that means the runways are facing 20 and 200 degrees. We want to take off into the wind. Using the weather report from question # 2, what runway do we want to use?

6. Once we get into the air, we fly 110 knots at a heading of 120 degrees to get to First Flight airport. If the wind is coming from 300 degrees at 30 knots, what heading do we need to take in order to be on course? What will our speed be?

7. The Piper Archer burns 9 gallons per hour and holds 48 gallons of fuel. Will we be able to make the trip nonstop? If not, how far into the trip will we have to refuel? If the *Wright Flyer* burns 1 gallon per hour and holds 1 gallon in its fuel tank, how many fuel stops will it need to make along the route?

8. We have been traveling at a good rate of speed, but now the winds have shifted. The wind is now 90 degrees at 10 knots. In what general direction will we need to turn to stay on course?

9. Phew! First Flight Airport is finally in sight. We tune in the radio to get the weather report and this is what it says:

“Winds are 260 at 5, visibility is 10 miles; temperature is 25 C, dew point 16 C. Altimeter is 30.02.”

If First Flight airport has runways 4 and 22, on which should we land?

Congratulations! We made it! We have come a long way since 1903. Let's go refuel, have some lunch, and head on back to Ohio! Let's see, what runway are we using again...?

Credit AOPA's Aviation Services Department.

Photocopying for classroom use encouraged

CORE SUBJECTS: GEOMETRY, EARTH SCIENCE, GEOGRAPHY

WHAT IS A TRAFFIC PATTERN?

Almost everyone has heard of airport traffic patterns, but until they become pilots few know what they are. Years ago it was recognized that, without some sort of consistent arrival and departure procedures, the risk of collisions at airports was significant, especially at airports without operating control towers. What evolved was a standard airport traffic pattern formed as a rectangle around the runway in use.

Just as there are “rules of the road” for driving a car, there are rules for how airplanes fly. This is especially important at an airport where the traffic can be very congested and confusing if there were no rules. Common to most airports, pilots fly a full traffic pattern that follow a rectangular path with five typical “legs.”

The legs start with the **upwind leg**, which runs parallel to the runway in the same direction you will land, followed by the **crosswind leg** that runs perpendicular to the runway, followed by the **downwind leg** that again runs parallel to the runway but in the opposite way you will land, followed by the **base leg**, which again runs perpendicular but on the end of the runway you will touch down, and finally the **final leg** that takes you on a straight line to the runway and your landing. Unless otherwise directed, all turns in a standard traffic pattern are made to the left.

Finding the runway specified by the control tower for landing is surprisingly easy, because runway numbers are selected to match the airplane’s compass heading on landing. Simply take the compass heading and delete one zero to find the runway number. For example, a pilot approaching Runway 27 would be landing in a westerly direction, and therefore would see 270° displayed on the magnetic compass.

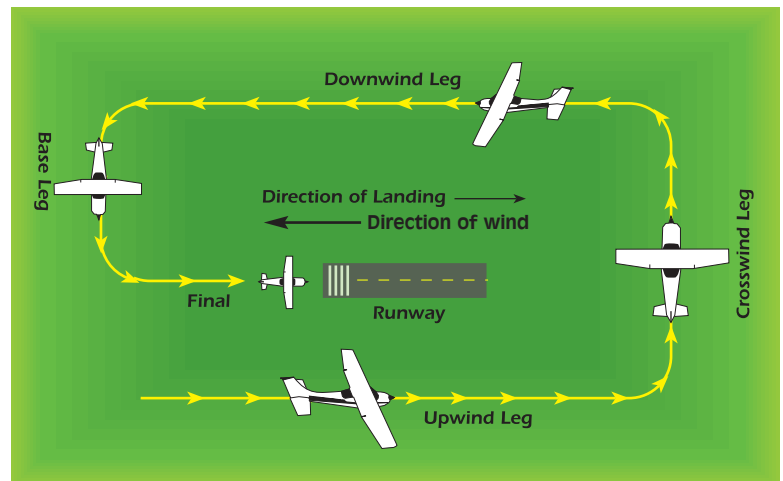

Approaching that same runway from the opposite direction, however, you would see “9” painted on the runway, and 090° on your compass. That’s because there’s always a 180° difference in numbers on each end of a runway. (The runway in this example would be known as “Runway 27/9.”)

In most cases, the runway in use is selected to allow the pilot to land most directly into the wind since pilots always want to land

into the wind, if possible. So, if the wind is blowing from the west in this example, the pilot will want to land on Runway 27. If it’s from the east, Runway 9 is preferable. And, if the wind is from the south? Runway 18 would be preferred, if there is one; otherwise, the pilot will need to make a “crosswind landing.”

Note: adapted from “You Can Fly!” by Gregory N. Brown and Laurel Lippert

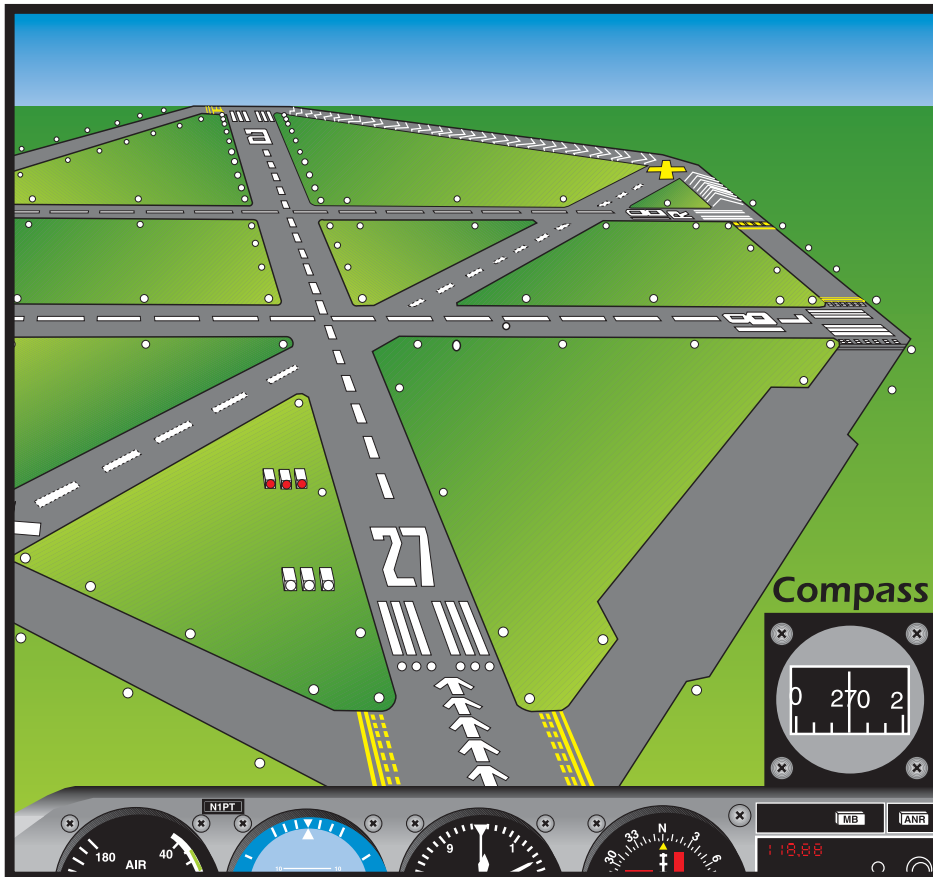

ACTIVITY: Draw your own traffic pattern

Photocopy this activity for classroom use.
Go to www.aopa.org/path for student worksheets.

TEACHERS:

From this activity, students will learn how an airport traffic pattern works by tracing its path.

Students will use a protractor and compass to determine wind direction and runway locations.

MATERIALS:

Big pieces of chalk

Protractor/Compass

Open areas of concrete or asphalt away from traffic, such as a corner of the parking lot

Copies of this sheet with traffic pattern diagram (from excerpt)

TO DO IT:

- ▶ Divide students into teams of three or four.
- ▶ Each team gets chalk with which to draw a runway on the concrete.
- ▶ Now draw a traffic pattern using the picture on page 45 as a guide.
- ▶ Label each leg of the pattern, and mark the runway numbers on the runway.
- ▶ Figure out what direction the wind is coming from. If the wind is calm, pick a runway direction, and practice walking the pattern, climbing, turning, leveling off, and descending as an airplane would to land.
- ▶ Draw another runway that intersects the first. You can use a protractor to measure the angles the two runways cross each other and the angle at the wind crosses a given runway. This translates into the amount of crosswind that the pilot will need to manage during landing.

If you can't take your students outside, try this same exercise on the blackboard or on individual sheets of paper. Just skip "walking" the traffic pattern

QUESTIONS:

- 1 On what leg is the airplane moving the...
 - a. fastest over the ground?
 - b. slowest over the ground?
2. Why would a pilot want to land into the wind?
3. How would a crosswind affect the ground track of the airplane in the traffic pattern?
4. What happens when there is more than one airplane coming in to land? Not all airports have control towers, so how do you think the pilots would sort it out?

ANSWERS:

1a. On the downwind leg, because the wind pushes the airplane from behind. **1b.** Groundspeed is slowest flying into wind on the final approach. **2.** Just as a person gets pushed back or slowed down when walking into the wind, an airplane slows when wind is coming directly at its front. A slower groundspeed at touchdown means the airplane can stop in less runway. **3.** Since wind pushes the airplane from the side when the airplane flies across the wind, the airplane's track over the ground is angled as well. Pilots correct for this by pointing the nose of the airplane into the wind a few degrees. **4.** Pilots use the radio to talk to each other, giving position reports and letting other pilots know what they intend to do. Regulations stipulate which aircraft have the right of way, depending on what kind of aircraft it is and where the aircraft are in the traffic pattern.

Note: Adapted from "Women/Leaders Take Flight" seminar, presented by Linda Castner.



A pilot flies over the runway
in Kansas City, Missouri,
before landing.

CORE SUBJECTS: COMPUTER SCIENCE, GEOGRAPHY

HOW MANY HOURS OF FLYING TIME

have your students “logged” so far? The answer may surprise you. One of the first popular games designed for personal computers was the flight simulator program developed in the early 1980s and made famous by Microsoft’s® Flight Simulator. You may even have a similar program on your computer at home. Heck, maybe your ace flying is what prompted you to pick up this handbook.

Have you ever wondered how much flying on the small screen relates to real flying? Quite a bit, in fact. The U.S. Navy, in a famous study in the late 1990s, determined that it saved its new pilots several hours of training time in expensive aircraft by giving them copies of Microsoft Flight Simulator for prac-

ticing maneuvers and scanning instruments. You and your students can do the same thing. It helps to have a plan though. You can’t just barrel around, hoping to gain some piloting prowess out of the virtual blue sky.





This life-like cockpit photo actually is from a computer flight simulator.

ACTIVITY: Flight sim jockey

Photocopy this activity for classroom use.
Go to www.aopa.org/path for student worksheets.

TEACHERS:

From this activity, students will learn how computer flight simulator programs relate to real-world flying. Students will learn how to scan instruments for information while simultaneously controlling the flight of the airplane with their hands. They will get an appreciation for the challenges and the excitement of flying and improve their hand-eye coordination in the process.

If you do not have access to Microsoft Flight Simulator or a similar program, ask a local pilot if he or she would be willing to make a donation to your school computer lab. Pair this activity with the module on runways and traffic patterns. It helps for students to have learned the basics of traffic patterns before attempting to fly the simulator airplane.

MATERIALS:

Flight simulator program for PC or Mac
Joystick (flight yoke not required)
Aeronautical chart of your local area, including
nearest airport, if available

TO DO IT:

- ▶ Load your favorite airplane—or a trainer aircraft like a Cessna 172 or Piper Warrior—and search for your local airport in the database. Set that airport as your launch point.
- ▶ Access the checklists within the program to start the engine and taxi out to the runway. (What does the local weather tell you about the winds? Can you figure out which runway would be preferred?)
- ▶ As you accelerate down the runway, look at the airspeed indicator and note the speed at which you lift off into the sky.
- ▶ Climb straight ahead to 500 feet above the ground—check your altimeter to see when you've reached that altitude—and push the nose over a little to level-off so you can check for traffic in front of you.
- ▶ Continue your climb and begin a left turn, in a bank of about 30 degrees (using the attitude indicator), to a heading 90 degrees less than the runway heading. You'll need the heading indicator to know for sure when you get there (e.g. from Runway 27 turn "left to 180 degrees").
- ▶ Depending on the graphics, you should be able to look at your map and pick out features on the ground like bodies of water. Most pilots fly using these ground references rather than fixating on the heading indicator. Keeping your eyes focused outside the cockpit helps you see other traffic (airplanes) before they come too close.
- ▶ Once you reach 1,000 feet above the ground, level off your altitude. You should be ready to turn 90 degrees to the left again, for your downwind leg of the traffic pattern. Again, depending on the program, you may be able

ACTIVITY: Flight sim jockey

to switch views to see out your left window—the runway will be passing off your left wing in a couple of moments.

- ▶ Fly down the runway on the downwind leg, until the runway is about a mile and a half behind you, over your left shoulder. Lower your flaps 10 degrees.
- ▶ Using the tachometer, pull the power back to about 1,800 rpm and hold the nose level. Let the airspeed come down to about 85 knots, and lower your flaps another 10 degrees.
- ▶ Turn 90 degrees left again for the base leg, and continue your descent at 500 fpm (feet per minute) using the vertical speed indicator.

▶ When you are almost perpendicular to the runway, after a few seconds, turn a last 90 degrees to the final leg of the approach, keeping about 85 knots on the airspeed indicator.

▶ Lower your flaps another 10 degrees so now you have flaps extended a full 30 degrees. Let the airplane slow down to 70 knots.

When you touch down, you've successfully completed your first virtual traffic pattern—one of the most challenging parts of learning to fly. If you want more, check out the training modules within your favorite flight sim game, or check out sim sites on the web for add-on aircraft, scenery, and scenarios.

Runway 23—Your aircraft is heading approximately 230 degrees.





Photocopy this activity for classroom use.
Go to www.aopa.org/path for student worksheets.

CORE SUBJECTS: HISTORY, SOCIAL STUDIES, RESEARCH

EVERY STUDENT NEEDS A HERO, someone to look up to, someone who can teach them the lessons of life by tackling its adventures and overcoming its challenges. As a teacher, you do that every time you step into a classroom. Exploring the world of aviation also provides ample opportunities to highlight the extraordinary pioneers—scientists, mathematicians, inventors, builders, and of course, pilots—who laid the groundwork for modern flyers.

STUDENTS CAN FIND OUT MORE ABOUT THESE PILOTS AND PIONEERS AND THEIR INDIVIDUAL ACCOMPLISHMENTS AND CONTRIBUTIONS TO AVIATION FROM YOUR SCHOOL LIBRARY OR ON THE INTERNET.

Leonardo da Vinci (1452-1519) was the first person to study the problems of flight scientifically. He was fascinated with flapping-wing aircraft called ornithopters, which use the same principles of flight that birds use. He also conceived potential designs for helicopters, propellers, and a parachute.

Sir Isaac Newton (1643-1727) developed theories of motion that formed the basis for principles of flight centuries later.

Daniel Bernoulli (1700-1783) developed one of the underlying principles of airplane wing design, the Bernoulli Effect, in which any increase in the velocity of a horizontal fluid flow results in a decrease in the static pressure.

Sir George Cayley (1773-1857) is known as the “Father of Modern Aviation.” He formu-

lated the basic principles of aeronautics upon which modern flight is founded. Cayley built and flew the world’s first practical and successful airplane—a model glider—in 1804.

Wilbur (1867-1912) and Orville Wright (1871-1948), with the availability of the internal combustion engine, designed a control system for airplanes. The brothers’ accomplishment marked the first time that lift, power, and control were combined to enable the first controlled and sustained flight—which took place using their *Wright Flyer* in December 1903.

Florence “Pancho” Lowe Barnes (1901-1975) organized the Women’s Air Reserves in 1934 to fly aid to victims of national emergencies; she also established the Civilian Pilot Training program.

See an expanded list of aviation pioneers at www.aopa.org/path under “Classroom Tools”.

Harriet Quimby (1875-1912) became the first American woman to earn a pilot's license and was the first woman to fly across the English Channel.

Charles Lindbergh (1902-1974) was best known for accomplishing the first solo, non-stop transatlantic flight from New York to Paris in 1927. He covered the distance of 3,610 miles in 33 hours, 30 minutes.

Amelia Earhart (1897-1937) was the first woman to fly solo across the Atlantic Ocean, and the first woman to fly nonstop across the U.S..

Bessie Coleman (1892-1926) was blocked from learning to fly in the U.S. so she went to Europe. In 1921 "Queen Bess" became the first black woman ever to earn a pilot's license. She returned to the U.S. and began to teach other African-Americans how to fly.

Clyde Cessna (1879-1954) launched the aircraft manufacturing company bearing his name in 1927. Cessna produced its 150,000th single-engine piston aircraft in July 2004.

William T. Piper (1881-1970), was considered "the Henry Ford of aviation," he mass produced affordable aircraft and popularized the use of airplanes as a method of transportation.

Chuck Yeager (b. 1923) was the first pilot to exceed the speed of sound in level flight, which he accomplished in a Bell X-1 in 1947.

Willa Brown (1906-1992) was an aviator, educator and activist, she helped establish

the first all-black flying school – which helped train pilots for World War II. She was the first African-American woman to earn a commercial pilot's license.

The Tuskegee Airmen, or the 99th Fighter Squadron and 332nd Fighter Group, were composed of African-American pilots who fought with great success in World War II—they never lost a bomber under their escort to enemy fighters.

Elwood R. "Pete" Quesada (1904-1993) developed the concept of close air support for military ground forces and literally wrote the book in 1943 for the Army on how to employ air power. He was the first head of the Tactical Air Command and one of its few Hispanic three-star generals. Quesada was the first head of the Federal Aviation Administration.

Neil Armstrong (b. 1930), a civilian test pilot and NASA astronaut on the Apollo 11 mission, was the first person to set foot on the moon, in July 1969.

Alan (b. 1962) and Dale Klapmeier (b. 1963) founded Cirrus Design aircraft company in 1984, which would go on to certify, in 1998, the first single-engine production airplane to have a whole-aircraft parachute recovery system.

Eileen Collins (b. 1956) was the first woman to pilot a space shuttle, and the first to be selected as commander of a space shuttle mission.

See an expanded list of aviation pioneers at www.aopa.org/path under "Classroom Tools".

ACTIVITY: Who in the aviation world?

Photocopy this activity for classroom use.
Go to www.aopa.org/path for student worksheets.

TEACHERS:

Use the names below as sample subjects when teaching students basic research skills. Add pilots or aviation innovators to your lesson plan for different periods in history. See an expanded list of aviation pioneers at www.aopa.org/path under “Classroom Tools”.

Leonardo da Vinci
 Sir Isaac Newton
 Daniel Bernoulli
 Sir George Cayley
 Florence “Pancho” Lowe Barnes
 Wilbur and Orville Wright
 Harriet Quimby
 Charles Lindbergh
 Amelia Earhart
 Bessie Coleman
 Clyde Gessna
 William Piper
 Chuck Yeager
 Willa Brown
 The Tuskegee Airmen
 Elwood R. “Pete” Quesada
 Neil Armstrong
 Alan and Dale Klapmeier
 Eileen Collins

MATERIALS:

Internet search engines, school library or media center resources, magazines, newspapers, any and all research sources available.

WHAT TO DO:

- ▶ Have each student identify a pilot or aviation pioneer in whom they have some interest.
- ▶ Ask each student to research that individual and provide an oral or written report back to the class.

DEVELOP A LIST OF QUESTIONS FOR STUDENTS TO ANSWER. YOU MAY WANT TO INCLUDE THE FOLLOWING:

- ▶ What aviator did you choose to research?
- ▶ What contribution did this person make to aviation?
- ▶ Why did you select this person? What personal qualities or actions did you find most worthwhile?
- ▶ Did this person overcome some obstacle to accomplish whatever they did? If so, what was it?
- ▶ For inventors, how is whatever this person invented or discovered used in flying today?
- ▶ If you could invent something, what would it be and why?
- ▶ If you could be first in doing something, what would you do and why?
- ▶ Think of an idea in aviation and explain its benefits and challenges.



Orville and Wilbur Wright, pictured above with their *Wright Flyer*, will forever be legends of aviation worldwide.

PATH TO AVIATION

HOW AOPA CAN HELP YOU

Request the following handouts from AOPA at www.aopa.org/path or call 301/695-2000

- Take 'Em Flying
- What is General Aviation?
- ABCs of Aviation
- Choosing a Flight School
- Choosing a Flight Instructor
- Guide to Flying Careers

READ ALL ABOUT FLYING

You Can Fly! by Gregory N. Brown and Laurel Lippert is an excellent reference for students (and teachers) who want to learn more about general aviation. AOPA will donate a copy of the book to any school that requests it. Additional copies may be ordered from Aviation Supplies & Academics.

Contact: 800/426-8338; www.asa2fly.com



ADDITIONAL RESOURCES

The multimedia material including a teacher's guide can be obtained at www.inventingflightschools.org

Here are some pilot favorites you can suggest to young people who want to learn more about aviation:

- Biplane*, Richard Bach
- A Gift of Wings*, Richard Bach
- Bax Seat: The Log of a Pasture Pilot*, Gordon Baxter
- Flying Carpet: The Soul of an Airplane*, Gregory N. Brown
- Flight of Passage*, Rinker Buck
- Weather Flying*, Robert Buck
- Conquest of Lines and Symmetry: Aerobatics*, Duane Cole
- Cannibal Queen*, Steven Coonts
- Going Solo*, Roald Dahl
- I Could Never Be So Lucky Again*, James Doolittle and Carroll Glines
- Fate is the Hunter*, Ernest K. Gann
- Zero Three Bravo*, Mariana Gosnell
- Flying America's Weather*, by Thomas A. Horne
- Stick & Rudder*, Wolfgang Langewiesche
- West with the Night*, Beryl Markham
- Listen! the Wind*, Anne Morrow Lindbergh
- Spirit of St. Louis*, Charles Lindbergh
- We*, Charles Lindbergh
- Apollo 13*, James Lovell and Jeffrey Kluger
- Wind, Sand, and Stars*, Antoine de St. Exupery
- Weekend Pilot*, Frank Kingston Smith
- Fly the Wing*, James Webb
- The Right Stuff*, Tom Wolfe
- Yeager*, Charles Yeager et al

RESOURCES

FOR MORE INFORMATION

AOPA PROJECT PILOT – HELPING TO BUILD GENERAL AVIATION

The Aircraft Owners and Pilots Association created AOPA Project Pilot to provide a simple and effective way to reach out to the next generation of student pilots. AOPA Project Pilot helps AOPA members share their passion for general aviation (GA) while ensuring a growing, stronger community of pilots for the future.



Participation in AOPA Project Pilot is easy. AOPA members who want to be a Project Pilot mentor identify a friend, family member or co-worker who has the desire to learn

to fly. Mentors provide guidance and encouragement to student pilots—from introducing them to a flight instructor throughout the flight training process.

For anyone interested in learning to fly, having a mentor to guide you and provide encouragement throughout the your flight training is the best way to succeed as a student pilot. Learning a new skill like flying is a challenge, but student pilots backed by AOPA resources are three times more likely to finish their training and earn their pilot's license.

Visit www.projectpilot.org for more details on effective mentoring, details on learning to fly, program registration, and to search for a potential mentor or interested student.

AOPA FLIGHT TRAINING

AOPA *Flight Training* magazine's web site offers additional resources for anyone interested in learning to fly. Visit our web site ft.aopa.org/FTfree for details on how to start a six-month FREE subscription to AOPA *Flight Training* magazine, which is produced monthly for student pilots and flight instructors.



6 FREE issues of AOPA *Flight Training* magazine!

see ft.aopa.org/FTfree for details • 1-800-USA-AOPA

FOR MORE INFORMATION...

There are many resources available to you on all aspects of aviation, including career and college scholarship information. Some contacts you can make are listed here. Also, if you have any questions or feedback, feel free to contact PATH to Aviation through AOPA's Pilot Information Center (800/872-2672) or via email at: PATH@aopa.org

National Coalition for Aviation Education
www.aviationeducation.org

Academy of Model Aeronautics
5151 East Memorial Drive
Muncie, Indiana 47302
800/435-9262
www.modelaircraft.org

Aerospace Industries Association
1000 Wilson Boulevard, Suite 1700
Arlington, Virginia 22209-3901
703/358-1000
www.aia-aerospace.org

Air Line Pilots Association
www.alpa.org

Air Transport Association
1301 Pennsylvania Avenue NW, Suite 1100
Washington, D.C. 20004-1707
202/626-4000
www.airlines.org

Aircraft Electronics Association
www.aea.net

Aviation Exploring Division
Boy Scouts of America
1325 Walnut Hill Lane
Irving, Texas 75015-2079
972/580-2433
www.learning-for-life.org/exploring/aviation/index.html

Civil Air Patrol Cadet Program
105 South Hansell Street
Maxwell Air Force Base, Alabama 36112-6332
334/953-5095
www.cap.gov

Experimental Aircraft Association (EAA)
Aviation Foundation, Inc.
920/426-4800
www.eaa.org
www.young eagles.org

Federal Aviation Administration
www.faa.gov/education

General Aviation Manufacturers Association
1400 K Street NW, Suite 801
Washington, D.C. 20005-2485
202/393-1500
www.gama.aero

Helicopter Association International
1635 Prince Street
Alexandria, Virginia 22314
703/683-4646
www.rotor.com

National Aeronautics & Space Administration (NASA)
www.education.nasa.gov

National Air & Space Museum
www.nasm.si.edu

National Association of State Aviation Officials
Center for Aviation Research and Education
301/588-0587
www.nasao.org

Aircraft Owners and Pilots Association
421 Aviation Way
Frederick, Maryland 21701
301/695-2000
Fax 301/695-2309
www.aopa.org
email: path@aopa.org

National Business Aviation Association
1200 Eighteenth Street NW, Suite 401
Washington, D.C., 20036-2506
202/783-9000
www.nbaa.org/careers
www.avkids.com

Organization of Black Airline Pilots
www.obap.org

Professional Aviation Maintenance Association
717 Princess Street
Alexandria, Virginia 22314
866/865-7262
www.pama.org

The Ninety-Nines, Inc.
International Organization of Women Pilots
www.ninety-nines.org

University Aviation Association
3410 Skyway Drive
Auburn, Alabama 36830-6444
334/844-2434
www.uaa.aero

Women in Aviation International
101 Corsair Drive, Suite 101
Daytona Beach, Florida 32114
386/226-7996
www.wai.org

CREDITS

Editor

Julie K. Boatman
Technical Editor, AOPA Publications

Project Manager

Sue Walitsky
Director of Public Relations, AOPA

Technical Review

Tom Horne
Editor at Large, AOPA Publications

Design and Production

AOPA Creative Solutions Group

Graphic Designer

Rebecca Henigin

Version 0107



AIRCRAFT OWNERS AND PILOTS ASSOCIATION



Aircraft Owners and Pilots Association
421 Aviation Way, Frederick, Maryland 21701
301/695-2000 Fax 301/695-2375
www.aopa.org

THANKS FOR JOINING US ALONG THE PATH TO AVIATION!

Whether you're a pilot or an educator—or both—you'll find this Pilot and Teacher Handbook is designed to highlight the connections between aviation and everyday classroom topics. Very few young people are exposed to aviation unless an adult with a passion for flying shares that experience and opens the door for exploration and learning. AOPA, the Aircraft Owners and Pilots Association, is proud to provide this handbook to foster a sharing of knowledge and help make you do just that.

AOPA is the world's largest aviation association, representing more than two-thirds of the 630,000-plus pilots certificated in the United States. In existence since 1939, AOPA serves its membership through education, advocacy, and services critical to pilots and aircraft owners.

AOPA would like to thank Jim and Karli Hagedorn for their generous sponsorship of the PATH to Aviation.